



# CLUTCHTECH

## TSB-202



1 HAKKINEN RD WINGFIELD SA  
PH: +618 8300 5000  
FAX: +618 8300 5050

### RACING CLUTCH RELEASE BEARING CHECKING GUIDE

MEASURE:

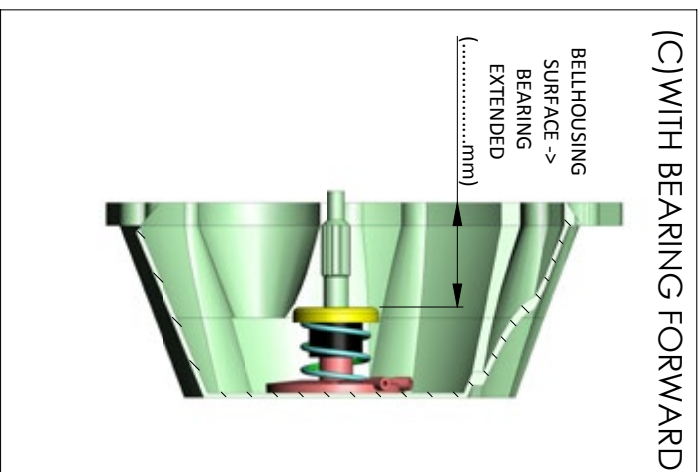
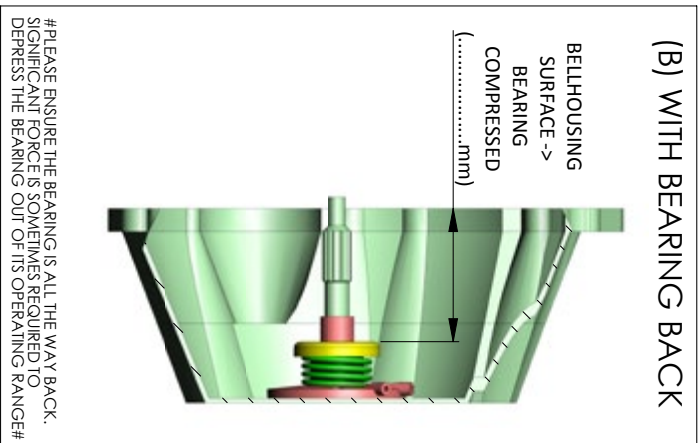
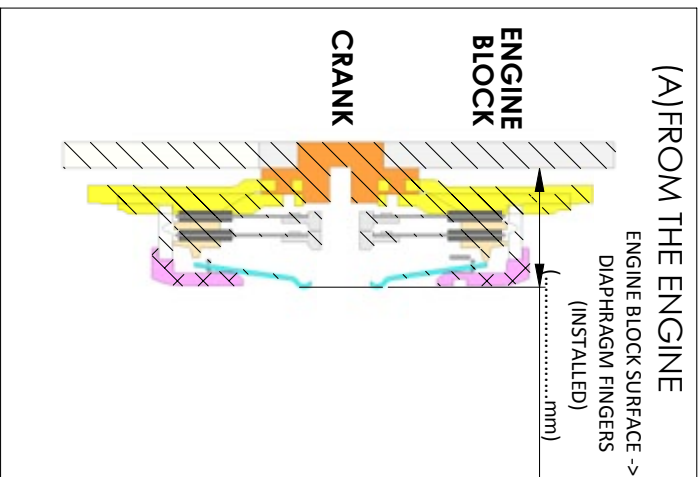

ROOM FOR CLUTCH WEAR = B-A = .....  $\geq 4\text{mm}$

CLUTCH RELEASE TRAVEL = A-C = .....  $\geq 8\text{mm}$

Please provide photos of the inside of the bellhousing, back of motor and any existing clutch components.



[youtube.com/watch?v=iUG2eqgTVNE](https://youtube.com/watch?v=iUG2eqgTVNE)

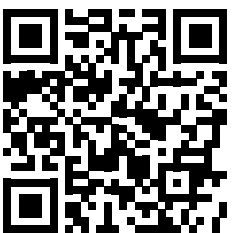

Scan with a QR app on your smart phone

[australianclutch.com.au](http://australianclutch.com.au)

1800 CLUTCH (258824)

# TECH BULLETINS

# TSB-202

